

E. F. WHITON.
Centering Machine.

No. 17,814.

Patented July 14, 1857.

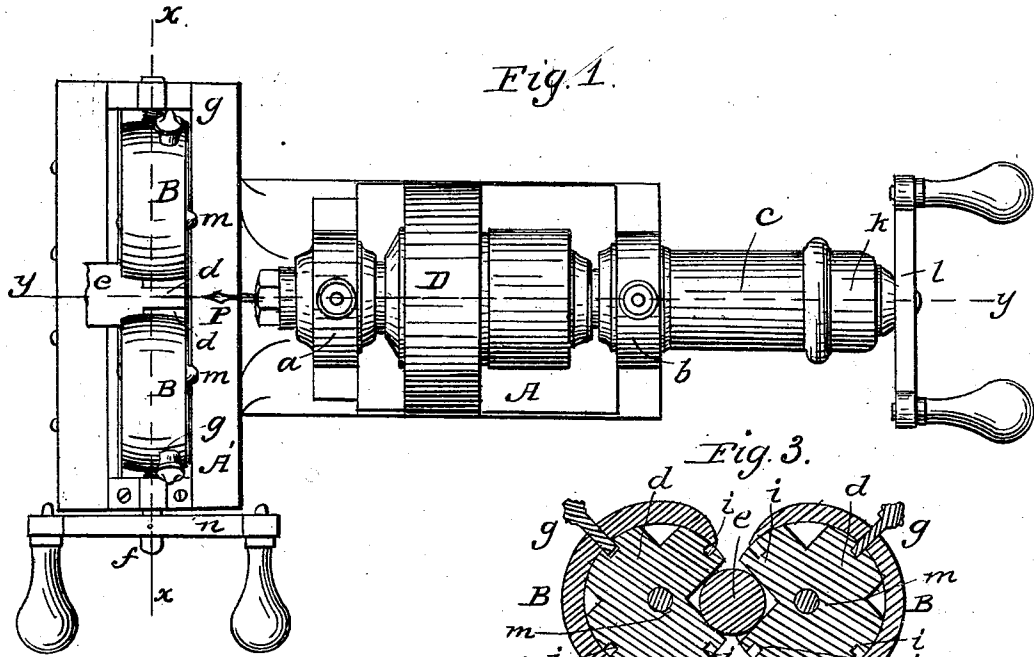

Fig. 1.

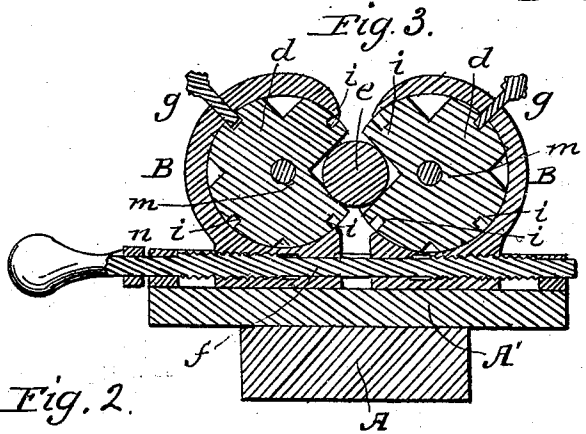

Fig. 2.

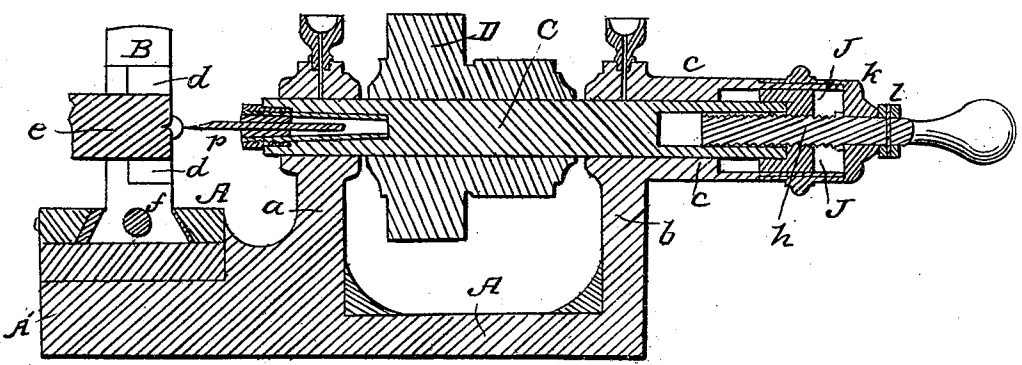

Fig. 3.

UNITED STATES PATENT OFFICE.

E. F. WHITON, OF WEST STAFFORD, CONNECTICUT.

CENTERING-MACHINE.

Specification of Letters Patent No. 17,814, dated July 14, 1857.

To all whom it may concern:

Be it known that I, EDWARD F. WHITON, of West Stafford, in the county of Tolland and State of Connecticut, have invented a
5 Machine for Ascertaining and Marking the Centers of Solid Shafts; and I do hereby declare that the following is a full and exact description thereof, reference being had to the accompanying drawings, making a part
10 of this specification, Figure 1 being a top view of said machine; Fig. 2, a longitudinal section in the line *yy* of Fig. 1, and Fig. 3 a transverse section in the line *xx* of Fig. 1.

Similar letters indicate like parts in all the
15 drawings.

A metallic frame, composed of the base A, A', the standards *a*, *b*, and the tubular offset *c*, from the standard *b*, receives the various movements of my said machine.

20 B, B, are adjustable boxes which receive the centrally pivoted and correspondingly notched holders *d*, *d*. The said boxes B, B, work in a transverse groove in the broad end A', of the base of the supporting frame of
25 the machine, and they are combined with the right and left-hand set screw *f*, in such a manner that, by turning said screw in one direction, or the other, the said boxes may be adjusted to any desired distance from
30 each other. The right-angular notches in the peripheries of the holders *d*, *d*, are of various sizes, and the notches of both of said holders exactly correspond with each other. Radial sockets *i*, *i*, are formed between the
35 respective notches in the peripheries of the holders *d*, *d*, which receive the retaining pins *g*, *g*, that pass through apertures in the rims of the boxes B, B, the said sockets being in such positions with relation to the notches
40 in the holders *d*, *d*, that the said pins will not pass into said sockets, save when notches of corresponding size, in the respective holders, are brought exactly opposite each other.

The forward end of the spindle C, works
45 in a suitable journal box secured within the head of the standard *a*, and the after end of said spindle is received into the tubular offset, (*c*.) from the head of the standard *b*. The bearings of the spindle C, and the boxes
50 B, B, which receive the notched holders *d*, *d*,

must be adjusted to such positions with relation to each other, that the axis of said spindle will be exactly in line with the central point between each matching pair of the notches in the respective holders *d*, *d*. A
55 tempered steel marker *p*, is secured within a socket in the forward end of the spindle C. An enlargement at the outer end of the tubular offset *c*, receives the screw-nut *j*, which is clutched to the outer end of the spindle C.
60 A cap *k*, which embraces the outer end of the tubular offset *c*, serves as a bearing for the set screw *h*, which passes through an aperture in the head of said cap, to the nut *p*, and through said cap into a perforation in the
65 right-hand end of the spindle C. The set-screw *h*, is turned by means of the lever *l*, and the set-screw *f*, is turned by means of the lever *n*. A pulley D, is combined with the spindle C.
70

To mark the end of a shaft, preparatory to its being placed in a lathe, or for any other purpose, the holders *d*, *d*, should first be secured in such positions within the boxes B, B, as to bring a pair of notches of suitable size opposite each other; then, the end of the shaft to be marked, must be inserted within said notches and the set-screw *f*, be so operated upon as to cause the sides of the said notches to closely embrace said shaft; then the spindle C, being driven at a high velocity, must be moved forward by turning the set-screw *h*, until a central mark of the proper size and depth has been formed
80 in the end of said shaft.
85

What I claim as my invention, and desire to secure by Letters Patent, is—

Arranging the laterally adjustable notched holders *d*, *d*, in such a manner in relation to the longitudinally adjustable spindle C, and its pointed marker *p*, as to enable the ends of shafts of various sizes to be centrally marked, substantially as herein set forth.

The above specification of my new and improved centering machine, signed and
95 witnessed this 4th day of May, 1857.

E. F. WHITON.

Witnesses:

SAML. FITCH,
JULIUS R. WHITON.